

miniDriller[®]

DM901HDE

DIESEL

ELECTRIC



Narrow



Productive



Robust



Safe

DIESEL DRIVEN & ELECTRIC DRILLER



Aramine

Grøpe Melkonian

miniDriller[®]

DM901 HDE

DIESEL

ELECTRIC



HIGH
RELIABILITY



LOW
MAINTENANCE



SAFE



DESIGNED
FOR THE
TOUGHEST
APPLICATION



A SIMPLE AND RELIABLE MINIDRILLER

The DM901 HDE is a Front face drilling rig, driven by a Diesel engine and drilling by an Electric powerpack with a cable reel.

Designed to match perfectly the Aramine miniLoader range, the DM901 miniDrill uses many common components from the hydraulic components to the tire size, but also the same overall dimensions with the unique width of 1,05 m.

Compact and easy to maneuver, the Boom allows drilling in 1,7m wide up to 3m wide galleries, which makes the DM901 miniDrill the only machine in the market able to mechanize small sections as 4m².

The HDE version is fitted for Horizontal Face drilling, but the DM901 is also available in Vertical Long Hole drilling.

Like all Aramine Equipment, the DM901 is tough and simple machine designed for underground environment, and especially for the very narrow vein mines.

The carrier is a strong welded frame with 4 wheel drive and central articulation.

The rear axle is oscillating, and the center of gravity is low for better stability.

DIMENSION AND DRILLING COVERAGE

CARRIER SPECIFICATIONS

- 4WD heavy duty carrier, articulated, rear axle oscillating
- FOPS certified canopy over operator
- Deutz engine, series TD2011 52 kW @ 2300 rpm, TIER 3
- Air intake : Dry Type Air cleaner
- Engine Exhaust : Catalytic Purifier with silencer
- Transmission : Hydrostatic transmission with 4 wheel end motors
- Brake System : Hydrostatic Brake system
- Parking Brake : Spring applied hydraulic release in each wheel motor
- Tires : 7.5 x R15 for underground application
- Central Articulation with Locking device
- Two Front Hydraulic stabilizers with width extension
- Cable Reel for 60 m electrical cable
 - Hydraulic system with Bowman Cooler
- Ansul Fire suppression system
- (1) Fire extinguisher
- Manual centralized Lubrication
- Engine Hourmeter in Dashboard and Drilling Hourmeter In electrical Cabinet.
- Working lights : 2 x Front LED Light N44, 50W, 24 V
- Tramming lights : 2 Front and 2 Rear Led Lights
- Tramming Speed :
 - Horizontal Ground : 7 Km/h
 - Incline 14% : 5 Km/h

DRIFTER

Drifter	Montabert HC25	Epiroc RR14
	Standard	Option
Percussion power	7,5 kW	11kW
Percussion press	150 bar	180 bar
Rotation speed	0-250 rpm	0-300rpm@125cc
Hole diameter	45-64 mm	51-64 mm
Lub Air cons.	300L/min	400L/min
Length with shank	703 mm (R32F)	750 mm
Percussion Freq.	65 Hz	70 Hz
Rotation torque	313 Nm	510 Nm@125cc
Shank adapter	R32 Female-T38 Male	R32
Water cons.	20-50L/mn (15bar)	25-50L/mn(15bar)
Weight	73 kg	81 kg

ELECTRIC SYSTEM

- Protection degree IP55
- Electric motor 55 kW (75 HP)
- Standard Voltage & Frequency: 400V50Hz or 440V60Hz
(Other voltage on demand)
- Starting method: Star - Delta Overload
- Protection & ground fault: VIGI Module
- Phase sequence indicator: Siemens
- Electric cable reel with bushing type collector
60m cable 4x35mm

AIR SYSTEM

- Standard Air Compressor
- Hydraulically driven 5, 1L/s (10,8 CFM)
- Working pressure 3 bar

RECOMMENDED DRIFT SIZE

- (Canopy mounted)

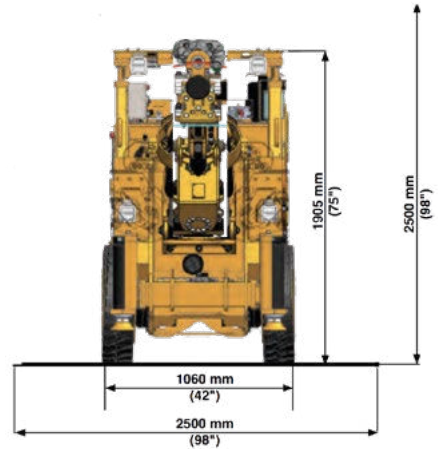

BOOM

- 1x BUA9F Boom for 4 to 9 m² Section
- (1,7 width x 2.2m High up to 3x3m)
- Telescopic Boom
- Angle lift +45°/-20°
- Swing angle +30°
- Rotary cylinders for vertical and horizontal rotation, 360° and 220°
- Hydraulic cylinders with Pilot check valves

FEED

- Standard Model HUA 220 aluminium Feed with cable, pulley & cylinders style
- Advance Drilling 700mm

	Unit	HUA180	HUA200	HUA220*	VUA110
Total Length	mm	3000	3200	3400	2200
Hole Length	mm	1800	2000	2200	1000
Rod Steel Length	mm	2000	2200	2400	1200

* STANDARD (Optional Telescopic Feeds - See back for details)

WATER

- Standard Water Pressurizer
- Hydraulic driven Water pump
- Maximum capacity 6,9m3/h
- Mini inlet press 2 bar

DM90IHDE**DIESEL****ELECTRIC**

ARAMINE DM90IHDE miniDriller® DRILLING POSITION

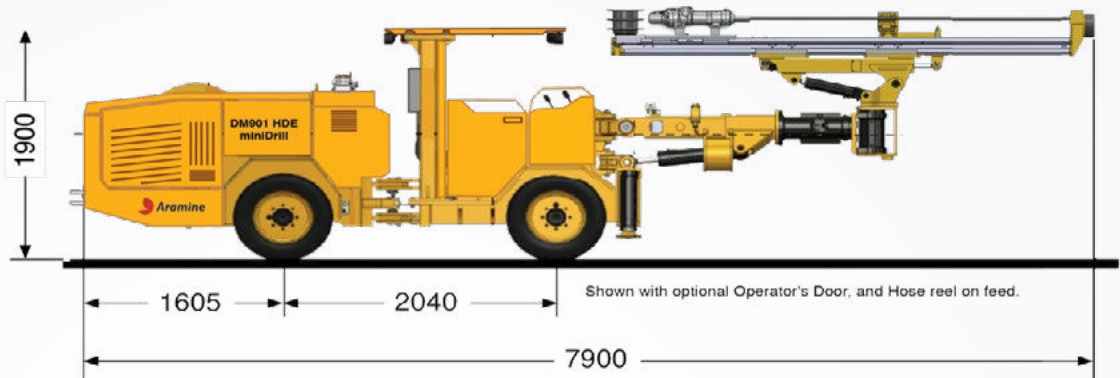

Width : 1.05 m

Height : 1.90 m / Length for Transportation : 7,50 m

Weight (Operationnal) : 7,1 t

Parts, Operation and maintenance in PDF and USB key

SELECTION OF OPTIONAL TELESCOPIC FEED

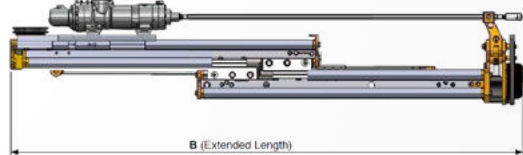
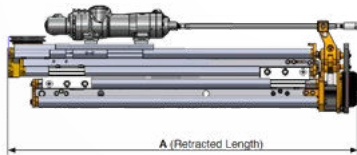

Aramine Feed Model	Length A Retracted (mm)	Length B Extended (mm)	Drill rod Retracted	Drill rod Extended	Max Drill Hole* Bolt Length
THUA 8-10	3330	3930	8'R32	10'R32	8'(2,4m)
THUA 7-9	3010	3620	7'R32	9'R32	7'(2,1m)
THUA 6-10	2710	3930	6'R32	10'R32	6'(1,8m)
THUA 5-8	2410	3320	5'R32	8'R32	5'(1,5m)
THUA 4-7	2020	3010	4'R32	7'R32	4'(1,2m)

* with Montabert HC Drifter

DRILLING SYSTEM

- 1x Hydraulic/Electric Powerpack 55kW-60Hz or 45 kW - 50Hz
- Direct Drilling controls from operator's compartment, with regulators valves
- Easy Manual Drilling Regulation with gage indicators
- Possibility to use percussion without rotation for Bolting

OPTION

- Ansil Fire suppression System
- Operator's Door with park brake interlock
- Radio Remote Control
- Telescopic Feed for Bolting or confined area
- Epiroc RR14 (14kW) drifter

*The drawings and images of this brochure may show equipment with specific options.
The specifications and equipment are subject to change without notice.*

ARAMINE DM90IHDE miniDriller® TRAMMING POSITION

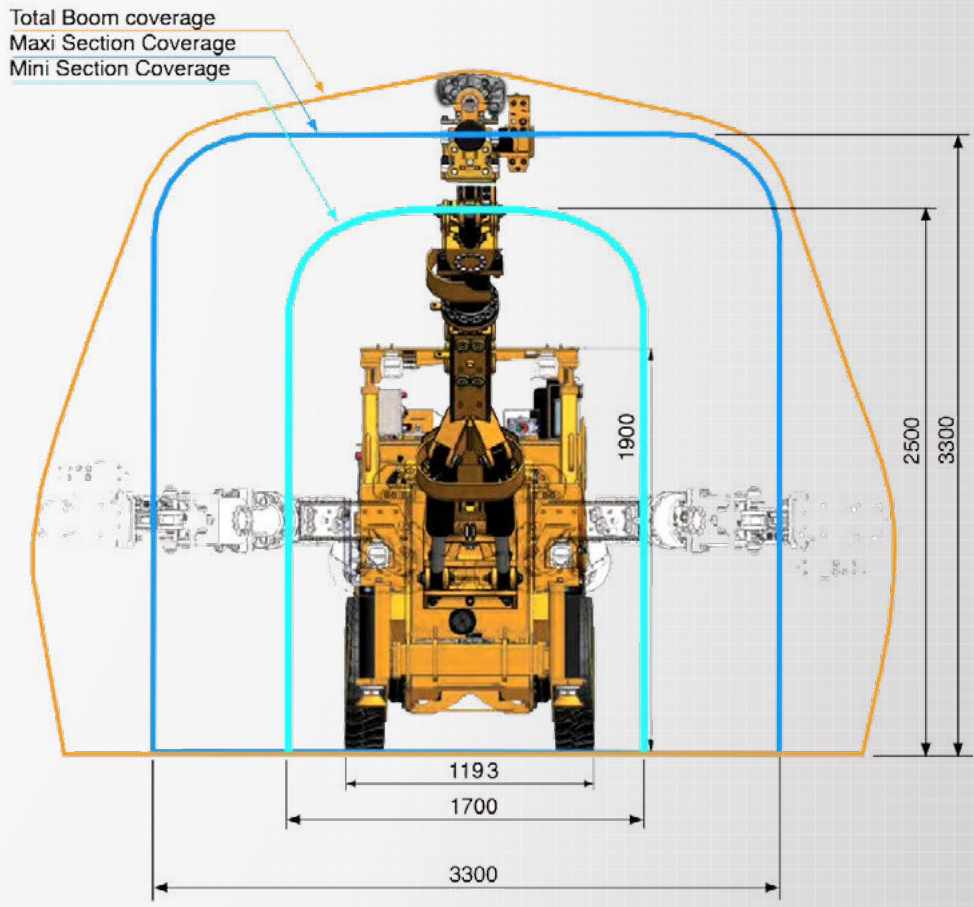
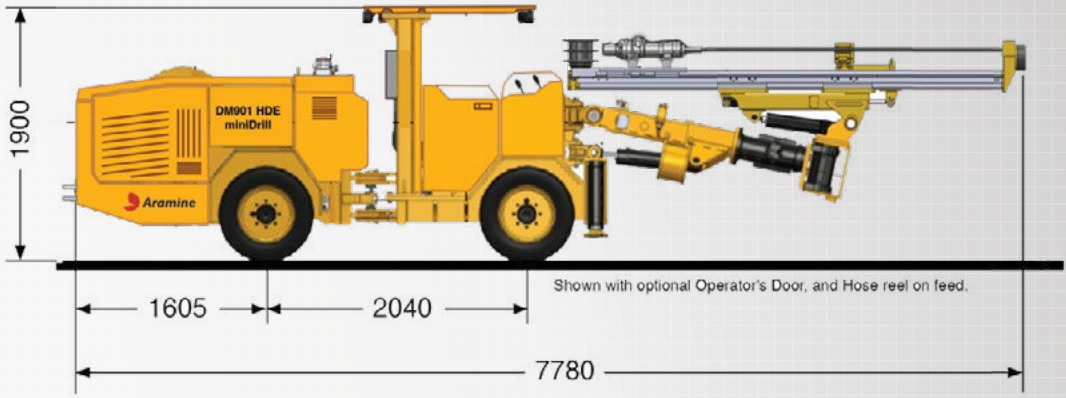



www.aramine.com



PAAP – 158 Rue Henri Bessemer - BP 60205
13796 Aix-en-Provence Cedex 3 – FRANCE
Phone : +33 (0)4 42 53 53 00
info@aramine.com



Aramine joins the Global Compact of the United Nations and is committed to develop its Social Responsibility

