

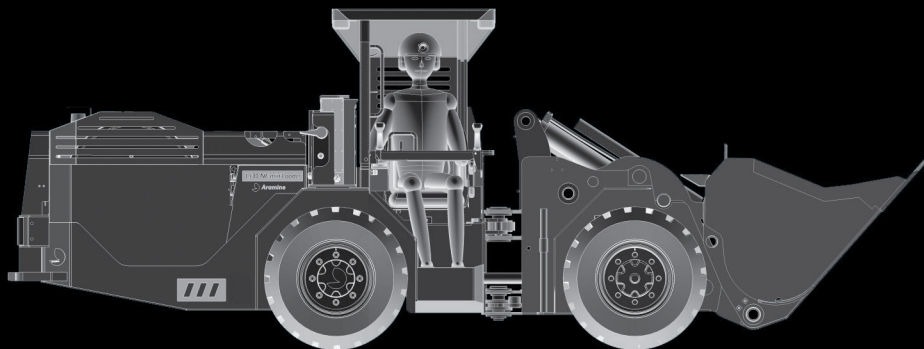

Leader in mining and underground solutions

L130E miniLoader®

Electrical power technical specifications



Capacity 1200kg

Bucket 0,5 to 0,75 m³

Width 1046 mm

Electrical Power

The miniLoader L130E, is specially designed for underground mining works in narrow section and narrow vein mining. With a width of 1.046 m and a tramping capacity of one tonne, the L130 is ideal to raise your productivity without the need of increasing your gallery sections. Its modern transmission and components result in a high reliability with simple maintenance and fully safe operation.

The chassis and articulations are designed for the toughest application, in order to allow a high availability with a longer life time. The operator's compartment is side seated to comply perfectly with the underground requirements, with smooth and ergonomically located joysticks to offer comfort and safety to the operator and maintenance personnel.

The miniLoader L130E fitted with a simple and robust cable reel designed for tramping and equipped with an automatic cable tension system, allows the utilization of the miniLoader with less noise and low ventilation.

SPECIFICATIONS

DIMENSIONS (0,6m³ bucket view)

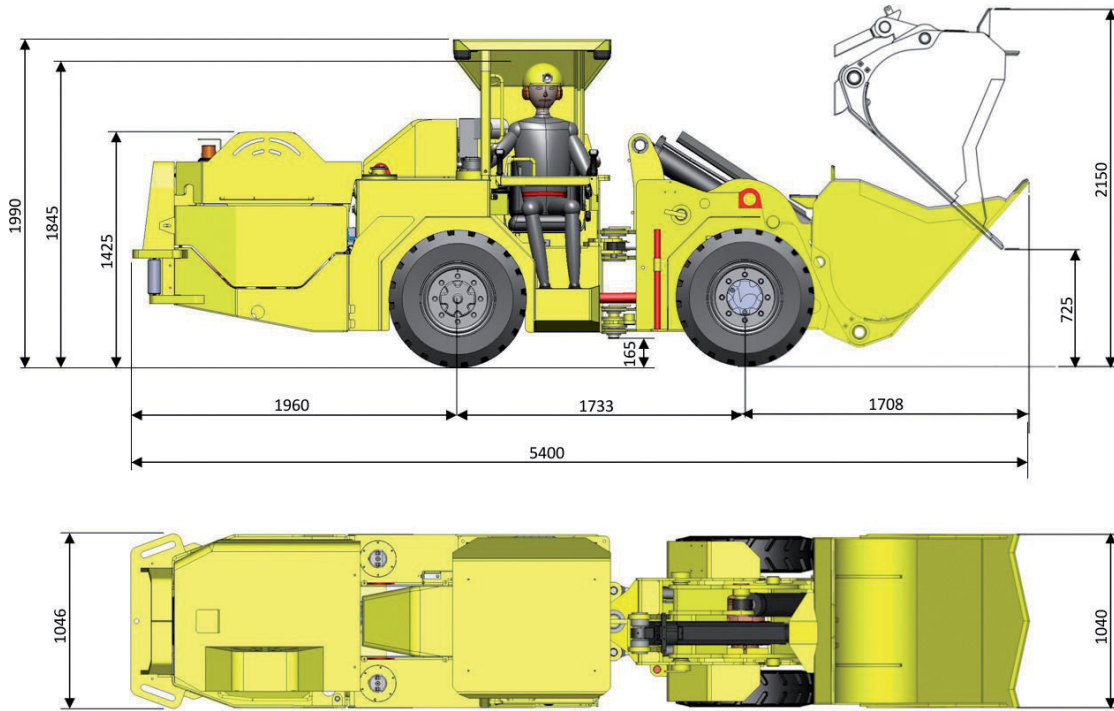

TURNING RADIUS (0,6m³ bucket view)

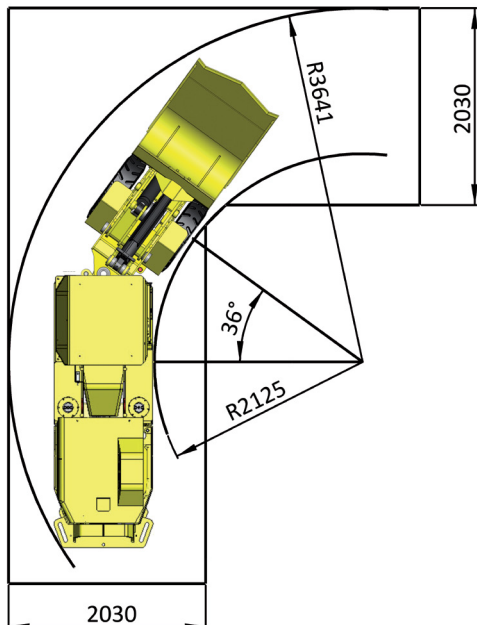

RECOMMENDED DRIFT SIZE

(Canopy mounted)

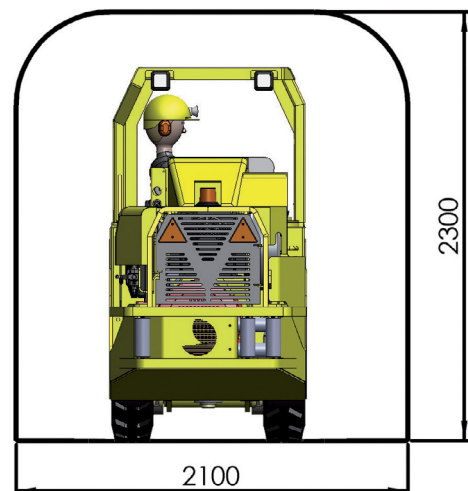

SPECIFICATIONS

CAPACITIES

Tramming Capacity 1 200 kg
Static Tipping, Load 30 kN
Breakout Force, tilt (SAE) 40 kN
Breakout Force, lift (SAE) 34 kN
Empty wweight 4 700 kg
 Empty, Front 1 300 kg /Rear 3 400 kg
 Loaded, Front 3 200 kg /Rear 2 700 kg
Standard bucket volume: 0,6m³

Density	1.6	2.0	2.4
Volume (m ³)	0.75	0.6	0.5
Width (mm)	1205	1040	1040

SPEED

Vehicle Speed Loaded: 0 to 6,5 km/h - 60 Hz
 0 to 5,5 km/h - 50 Hz
Bucket and Boom speed (50 Hz - 60 Hz)
Boom: Raising 4,5s - 3,7s / Lowering 3,5s - 2,9s
Bucket: Roll Back 5,2s - 4,3s / Dumping 6,8s - 5,6s

ELECTRICAL MOTOR & SYSTEM

Motor:

Three-phase asynchronous - Squirrel Cage
IP55 Degree of protection
Power, Frequency and speed:
37 kW power - 50 Hz - 1 500 tr/min
43 kW power - 60 Hz - 1 800 tr/min

System:

Electrical system compatible with 380V - 50 Hz and 440V - 60 Hz

CABLE & CABLE REEL

Hydraulic driven with self tension cable reel
Heavy duty cable guiding for underground mining application
Capacity: 80m of cable 4x16 mm²
(800 mm diam cable reel)

TRANSMISSION

Hydrostatic Transmission fully reversible
Pump: variable displacement 71 cm³
Motor: fixed displacement 58 cm³

FRONT AND REAR AXLES

Front & Rear axles, Aramine A5095 Series

Front: Rigid axle with wheel end planetary and Nospin[®] differential lock type

Rear: Oscillating mounted axle with wheel end planetary and standard differential

Dropbox: Mounted on rear axle

OSCILLATION

Rear axle mounted on oscillation frame with 12° articulation (6 degrees in each side)

ELECTRIC SYSTEM: 24V

Sealed electrical system with replaceable harness
2 Front & 2 Rear lights : 24V-H3-70W

HYDRAULIC SYSTEM

Suction strainer 100 microns
Return filter: 25 microns cartridge
Fluid: Class 68
Hydraulic tandem gear type pump
Hydraulic Pilot Steering & Bucket Controls
Hydraulic Cylinders, double acting type:

- One (1) for Stab
- One (1) for Hoist
- Two (2) for Steering

BRAKES

Service: Hydrostatic brake

Parking & Emergency: LCB multi-discs, Spring Applied hydraulic Release, mounted in rear axle
Manual and/or automatic actuation in case of energy loss (hydraulic, electric, engine) and when operator is out of the seat.

TIRES

Michelin 7,5R15 X-Mine D2
Mounted on demountable rims

TANK CAPACITIES

Hydraulic: 80 L (Welded to frame)
Hydrostatic: 70 L (Welded to frame)
All tanks with access cover (easy cleaning)

OPERATOR'S COMPARTMENT

Side Seated Operator, for better visibility in both directions
Seat with suspension, armrests and safety belt
Removable canopy
Ergonomically located Steer & Bucket pilot joystick

PERFORMANCES

SPEED ON GRADE

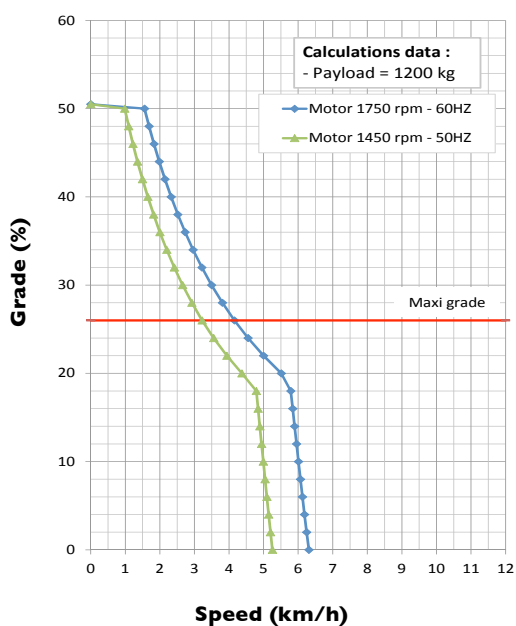

PRODUCTION inT/h

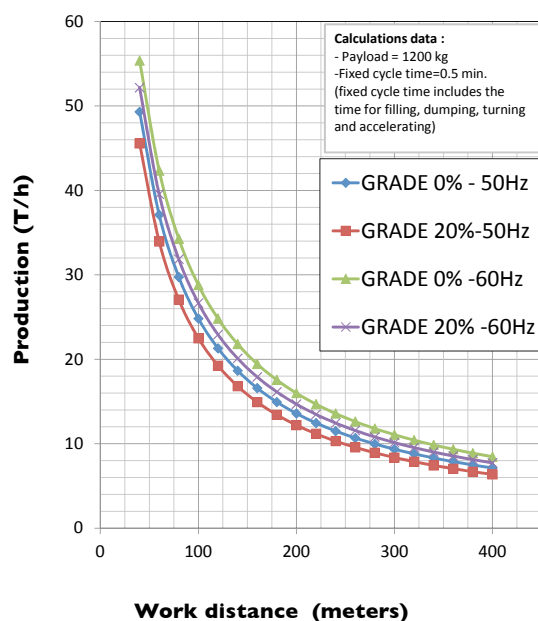

STANDARD EQUIPMENTS

- Certified ROPS/FOPS Canopy over operator
- Hydrostatic Transmission
- Pilot operated Steering Joystick (Left Hand).
- Pilot operated Bucket Joystick (Right Hand) with Fwd, Neut & Rev integrated buttons
- Seat with armrest and Safety belt
- Dashboard with Default Indic Gage, Front & Rear lights and Horn switch. Motor Stop/start switch
- Manual centralized lube system
- Audio & Visual back-up Alarm
- Replaceable inserts to central hinge, bucket and boom articulations
- Dump Cylinder Protection
- Safety Central hinge locking device
- Safety Boom Raised locking device
- Brake test System
- Safety joystick interlock
- Michelin 7,5R15 X-Mine D2

OPTIONS

- Extinguisher
- Automatic lube system
- Radio Remote Control system
- Bi-Xenon or LED compact light
- Entry door with bucket & steering interlock
- Gear basket «fit in» bucket
- Cylinders pilot check valves
- EOD Bucket
- Complementary Service & Park Spring Applied multidisc brake

L130E miniLoader® TECHNICAL SPECIFICATIONS
EN20160321

