

# miniDumper<sup>®</sup>

## T500D

DIESEL



Robust



Modern



Comfort



Safety

## A MINI MINE TRUCK FOR HIGH PRODUCTIVITY

 **Aramine**  
Groupe Melkonian

# miniDumper<sup>®</sup>

## T500D

### DIESEL



HIGH  
RELIABILITY



LOW  
MAINTENANCE  
COST



BEST  
COMFORT OF  
ITS CATEGORY



DESIGNED FOR  
THE HIGHEST  
CERTIFICATION



## A SIMPLE AND RELIABLE DUMP TRUCK

Based on the power frame and components of the L150D, the T500D miniDumper will easily allow you to increase productivity without the need of special skills and keep control of parts inventory and fleet rationalization. With its four wheel drive, heavy duty articulated frame and oscillating axle, the T500D will smoothly carry your load in toughest road condition and short turning radius of underground narrow vein mines. Indeed, this dumptruck is capable to carry three times the capacity of the L130D/E miniLoader at a highest speed.

This result in a simple mission: increasing productivity by 4 times on a 700 meters tramming distance.

No doubt, the perfect complement of the L130/L150 miniLoader range is here, and will allow Narrow Vein Mining to reach another step of mechanization.

Comply  
to EC  
register



# SPECIFICATIONS

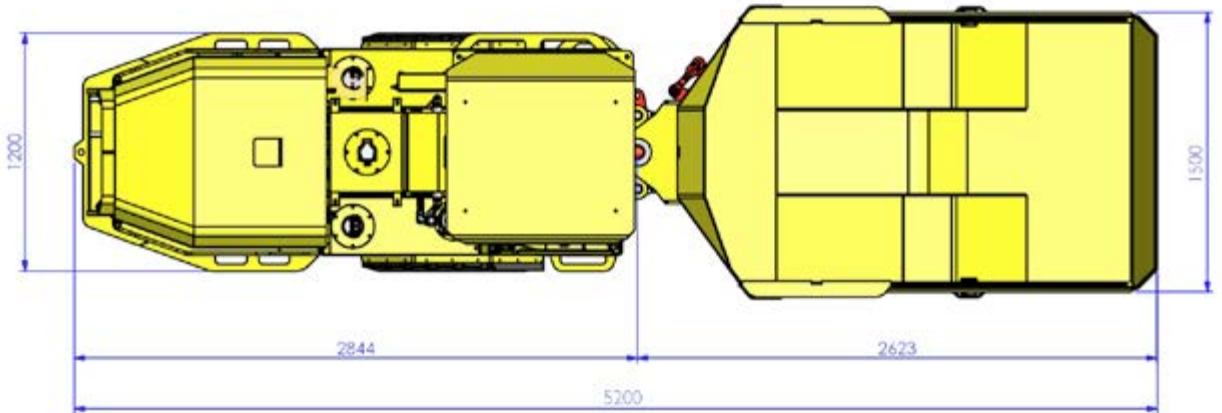
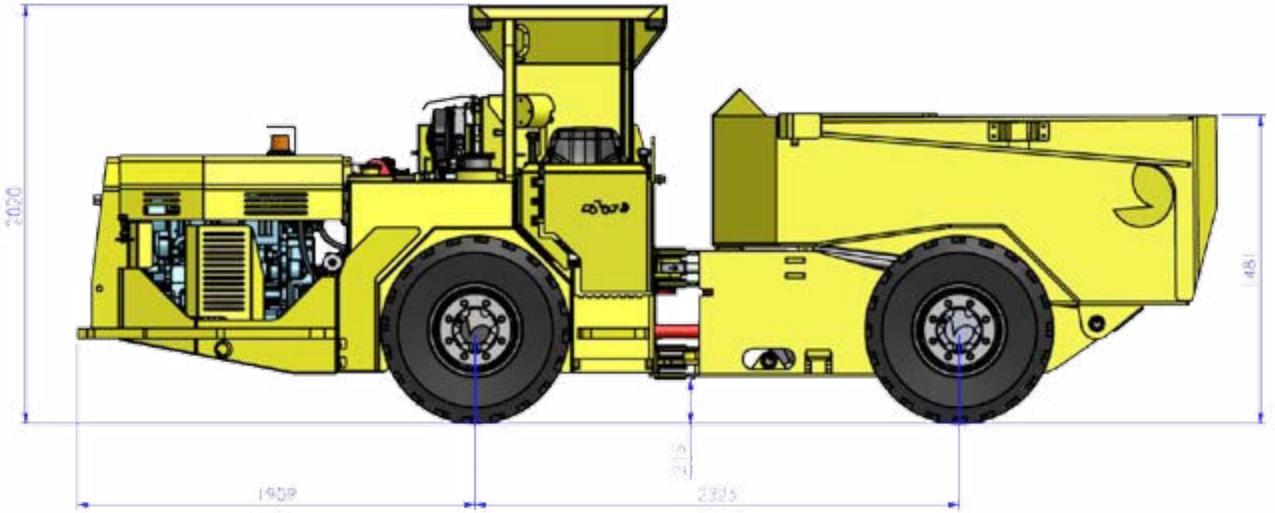

## CAPACITIES

Tramming Capacity	4 200 kg
Empty Weight	4 800 kg
Dump Box Volume Heaped	2,1 m <sup>3</sup>

## ENGINE & SYSTEM

Standard:

**Model D914L4** - CE: III3A and MSHA certified available - (53kW)

Options:

**Model BF4L914** - High altitude - (53kW @ 4 000m ASL)

**Exhaust:** Catalytic purifier and Silencer

## FRONT AND REAR AXLES

- Front & Rear axles, Aramine A5095 Series
- Front: Oscillating mounted axle with wheel end planetary and standard differential
- Rear: Rigid axle with wheel end planetary and Nospin differential lock type
- Dropbox mounted on rear axle

## SPEED

Vehicle Speed Loaded:	0 to 9 km/h
Dump Box and Boom speed:	
Door Opening + Dump Box raising:	7,7 sec
Dump box Lowering + Door Closing:	6,4 sec

**T500D****DIESEL**

## TANK CAPACITY

- Fuel: 50L (Bolted)
- Hydraulic: 80L (Welded to frame)
- Hydrstatic: 70L (Welded to frame)

All tanks with access cover (easy cleaning)

## HYDRAULIC SYSTEM

- Suction strainer 100 microns
- Return & Suction filter 25 $\mu$  Cartridge
- Fluid Class 68
- Hydraulic gear type pump 4lcc
- Hydraulic Pilot Steering & Bucket Controls
- Hydraulic Cylinders, double acting type:
  - One (1) for Dump Box (100mm pistons)
  - Two (2) for Steering (63mm pistons)

## ELECTRIC SYSTEM

- Sealed electrical system with replaceable harness
- Battery: 12V 105 Ah)
- Starter & accessories: 12V
- 2 front & 2 rear lights: 24V - H3 - 70W

## BRAKES

- Service: Hydrostatic brake with pedal control and Spring Applied multi-disc assistance
- Parking & Emergency : LCB multi-discs brake, Spring Applied Hydraulic Release, mounted in rear axle.
- Manual and/or automatic actuation in case of energy loss (hydraulic, electric, engine) and when operator is out of seat.

## TURNING RADIUS

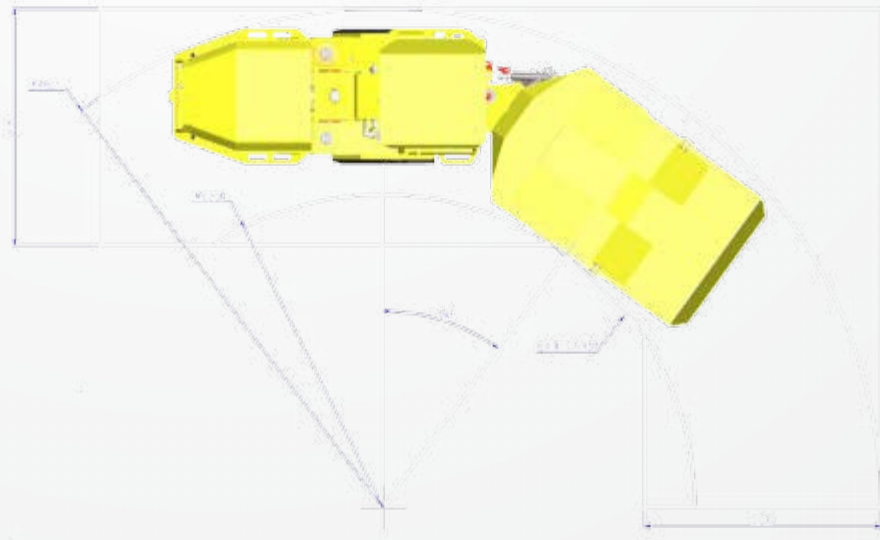

## RECOMMENDED DRIFT SIZE

- (Canopy mounted)

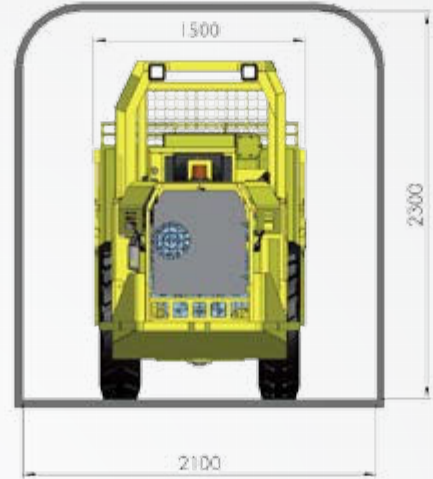

## TIRES

- Deep Lug tire of Mining application, 8.25R15 XMINE D2 MICHELIN
- Mounted on demountable rims Sealed electrical system with replaceable harness

## TRANSMISSION

- Hydrostatic Transmission fully reversible
- Pump: Variable displacement 71 cm<sup>3</sup> @ 400 Bars
- Motor: fixed displacement 56 cm<sup>3</sup>

## OSCILLATION

- Rear axle mounted on oscillation frame with 12° articulation (6 degrees in each side)

## SPEED ON GRADE

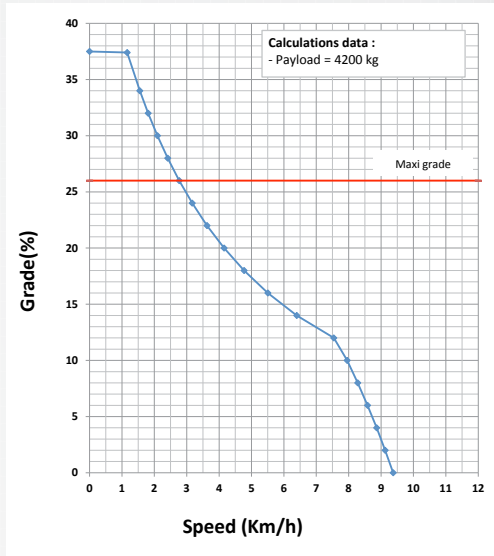

## PRODUCTION in T/h

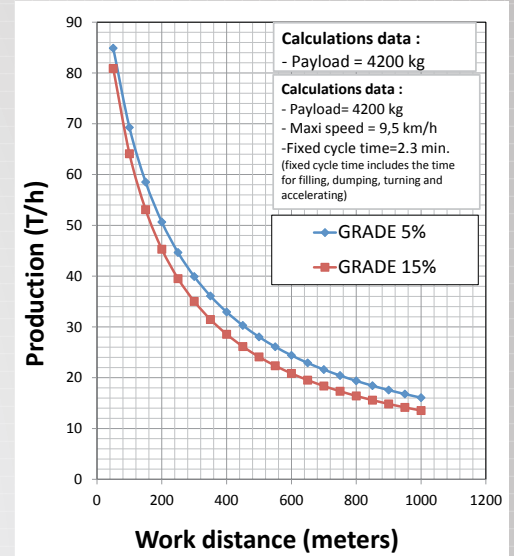

\*One way. For longer distance, contact our sales department

## STANDARD EQUIPMENTS

- ▣ Certified ROPS/FOPS Canopy over operator
- ▣ Operator compartment safety door
- ▣ Ergonomic and comfortable operator's compartment for enjoyable operation
- ▣ LED type lights
- ▣ Intuitive and ergonomic controls from joystick buttons for: Direction, Lights, Horn, and any option
- ▣ High level of safety integrated in all systems and designs
- ▣ All hoods are assisted by Gaz spring cylinder and locking device
- ▣ Dump Cylinder Protection
- ▣ Manual centralized lube system
- ▣ BackUp Audio/Visual Alarm
- ▣ Safe and easy Central hinge locking device
- ▣ Safe and easy Boom raised locking device
- ▣ Repleacable inserts to central hinge, bucket and boom articulations

## OPERATOR'S COMPARTMENT

- ▣ Side Seated Operator, for better visibility in both directions
- ▣ Seat with suspension, and safety belt
- ▣ Ergonomic built-in armrests ajustable with Joystick controls
- ▣ Ergonomic Control panel with 4,3' display for Diagnostic & Functions
- ▣ ROPS/FOPS Certified bolted Canopy with Back Protection
- ▣ Ergonomically located Steer
- ▣ Dump box pilot joystick
- ▣ Forward/Reverse/Neutral control buttons on left joystick
- ▣ Right foot pedal for trammng speed control
- ▣ Left foot pedal for hydrostatic brake

## OPTIONS

- ▣ Automatic lube system
- ▣ Extinguisher
- ▣ Fire Suppression system ANSUL
- ▣ Radio Remote Control system
- ▣ Emergency Power Steering (electro-hydraulic)
- ▣ Bucket with high abrasive blades reinforcement
- ▣ EOD Ejector Blade Bucket
- ▣ Brake Release Tow Hook

The drawings and images of this brochure may show equipment with specific options.  
The specifications and equipment are subject to change without notice.



[www.aramine.com](http://www.aramine.com)



PAAP – 158 Rue Henri Bessemer - BP 60205  
13796 Aix-en-Provence Cedex 3 – FRANCE  
Phone : +33 (0)4 42 53 53 00  
[info@aramine.com](mailto:info@aramine.com)



Aramine joins the Global Compact of the United Nations and is committed to develop its Social Responsibility



 | **Leader in mining  
and underground solutions**